

DATA SHEET – DIMENSIONS

ECO PTO SHAFT 910mm 30-75HP WITH FREEWHEEL CLUTCH

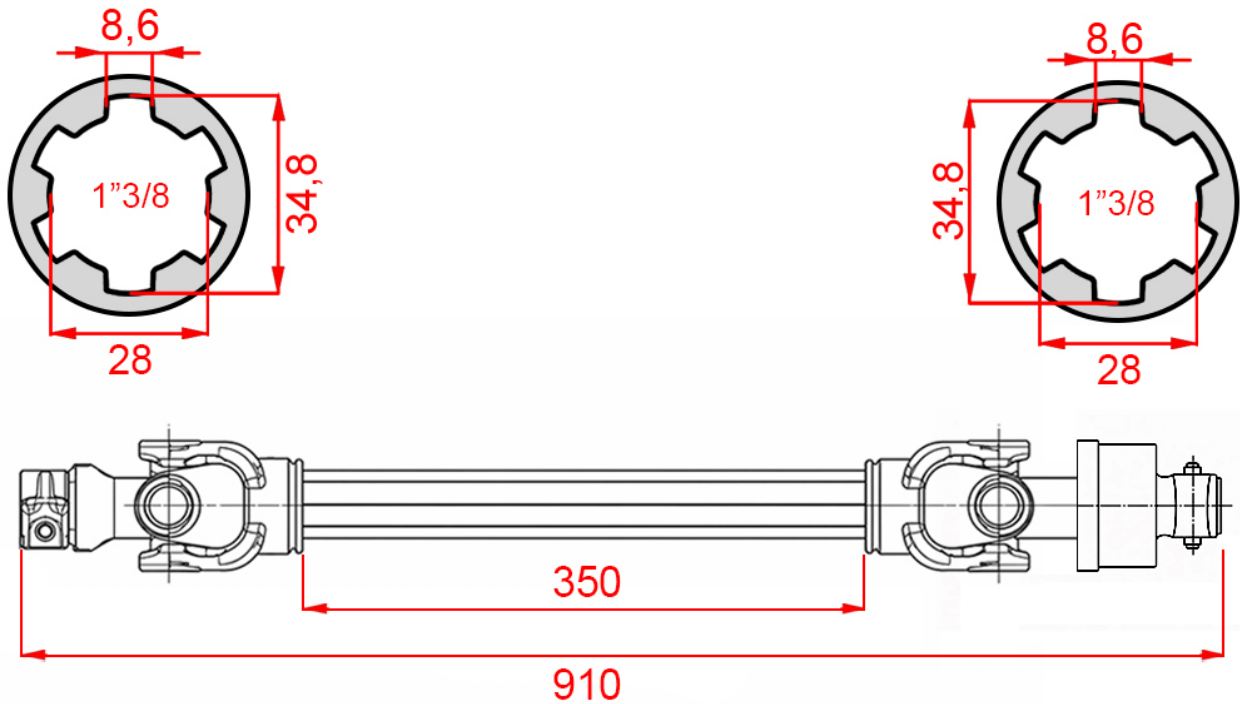

MIN. LENGHT (mm)	STANDARD	FOR TRACTORS (HP)	CROSS (mm)
910	CE 2138	30 - 75	26,97 x 81,75